

pitagora

ombrellone a braccio
laterale retrattile in alluminio
verniciato grigio antracite
e bianco

retractable aluminium
lateral arm parasol
anthracite and white
varnished



CARATTERISTICHE TECNICHE TECHNICAL DATA

sistema di chiusura retrattile
retractable closing system
possibilità di fissaggio al suolo
possibility of fixing on the ground
parti metalliche prima zincate,
poi verniciate
metal parts galvanized and
varnished

con stecca antivento tra palo
verticale e ragno
anti-wind rib between vertical
pole and frame

stecche intercambiabili
interchangeable ribs

stecche diagonali 4x4 rinforzate
reinforced diagonal
ribs for 4x4

ombrellone standard fornito
con pendente
standard version with flounce

360° girevole
360° rotating

COLORI STRUTTURA FRAME COLOURS

 grigio antracite
anthracite grey

 bianco
white

OPTIONALS

carter copribase

coverbase carter

finitura pendente:

flounce finishing:



merletti
crenelation





onde
wave

fioriera in alluminio

aluminium planter

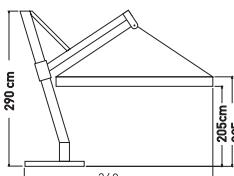
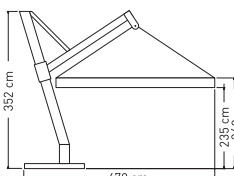
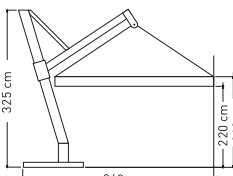
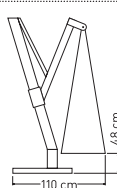
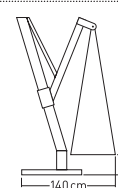

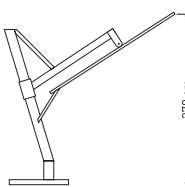
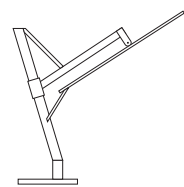
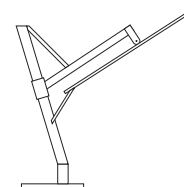
DIMENSIONE / SIZE	3x3	4x4	3x4
			
			
			
PALO (cm) / POLE	9,2x9,2	9,2x9,2	9,2x9,2
STECHE (NR.) / RIBS	8	8	8
PENDENTE - FLOUNCE	•	•	•
TESSUTO / FABRIC Acrilico - Tempotest® Parà Ombrelloni - PVC Acrylic - Tempotest® Parà Parasols - PVC	•	•	•